

Information

Hubs and Axles

Brake Assemblies

Suspensions & Fasteners

Tires & Wheels

Couplers, Jacks & Winches

Hitches & Towing Accessories

Body Components

Boat Trailer Parts

Lights & Electrical

Locks & Cargo Control

Brake Actuating Systems

Switches

Rubber Hydraulic Brake Line Kit

All brake line hose and fittings necessary to connect the actuator to brake clusters. Kits contain parts for one or two axles as shown.



- Designed to be used on trailers using either surge brake actuators or power brake actuators (vacuum/hydraulic, air/hydraulic, electric/hydraulic).
- Brake lines provided are D.O.T. flexible hoses approved for use on all trailer brakes including disc brakes with floating calipers.
- All fittings are brass for the ultimate in corrosion resistance. (Available with male & female end fittings)
- Maximum pressure not to exceed 3,000 psi.



D.O.T. Flex Hose Kits

Part #	Description
4801-P	Single Axle
4802-P	Tandem Axle
4803-P	Triple Axle
5291	Axle Add-on Kit - D.O.T. contains parts necessary to add brake lines for one axle to an existing kit.

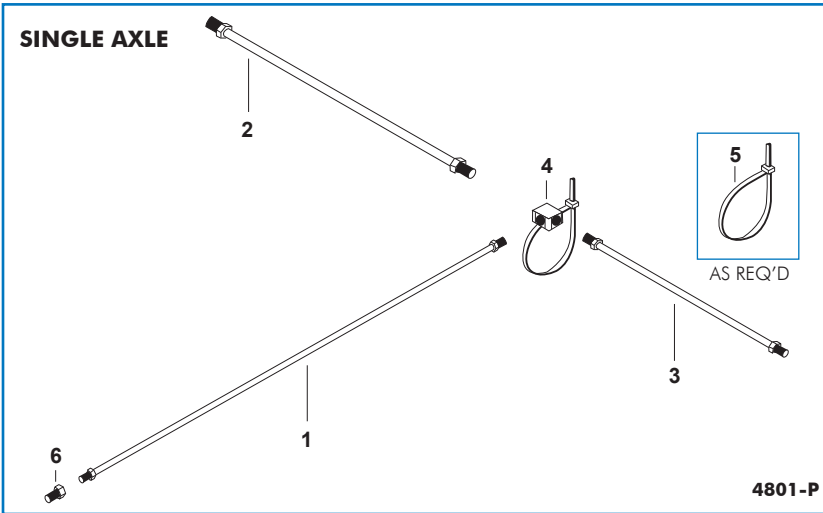

Service Parts For D.O.T. Flex Hose Kits (Single Axle)

DOT Part #	Item #	Description
5209	1	22' (264") Line
5208	2	72" Line
5206	3	24" Line
5263	4	Tee with Strap
2591	5	12" Tie Strap
5284	6	1/8 MPT x 3/16 IF Adapter

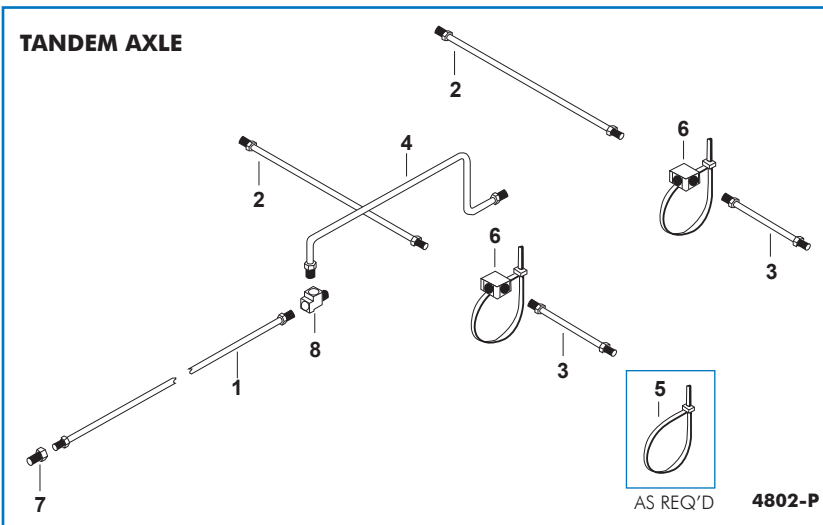

Service Parts For D.O.T. Flex Hose Kits (Tandem Axle)

DOT Part #	Item #	Description
5209	1	22' (264") Line
5208	2	72" Line
5206	3	24" Line
5207	4	36" Line
2591	5	12" Tie Strap
5263	6	Tee with Strap
5284	7	Brass Fitting 1/8 MPT x 3/16 IF Adapter
5124	8	3/16 IF Street Tee

Additional Parts

DOT Part #	Description
5204	18" Rubber Brake Line (male-male)
4952	Union - Connects two brake lines end to end
4857	12" Rubber Hose (male-female) non-swivel ends - cadmium plated ends

